

(00) 340382230000000009



# Logopak 510 TK

Keg and cask labeler for the labeling of variable height products



# Logopak 510 TK



## Printer features

- ✓ thermal transfer or direct thermal
- ✓ pre-set quick release print engine
- ✓ permanent print engine dot checking
- ✓ labeling speed: up to 30 labels/min (depending on label size, telescope stroke)
- ✓ print width: 4.2" (108 mm)
- ✓ print resolution: 300 dpi
- ✓ label throat width: 4.5" (115 mm)
- ✓ fonts: 10 fixed and 4 scaleable fonts
- ✓ barcodes: all common linear and 2D barcodes
- ✓ logotype
- ✓ 32-bit RISC processor 400 Mhz clock pulse
- ✓ 4 MB CMOS memory
- ✓ 128 MB work and graphics memory
- ✓ **RFID upgradable**

## Operational features

- ✓ color touch screen display
- ✓ multi lingual operator surface
- ✓ built-in real-time clock

- ✓ individual programmable counters
- ✓ internal article data base
- ✓ error logging
- ✓ end of label roll sensor
- ✓ low-pressure detection
- ✓ barcode reader optional
- ✓ variable stroke sensor optional
- ✓ 3-color alarm pole
- ✓ option: NEC-numeric display

## Communication interface

- ✓ ethernet (10/100 Mbit)
- ✓ 4 x high speed RS 232 (up to 115,200 bps), optional RS 422
- ✓ I/O signals potential free

## Applicator / Label sizes

- ✓ tamp
- ✓ stroke: up to 15.8" (400 mm)
- ✓ usable label sizes:  
1.4"x1.2" – 4.3"x5.9" (35 x 30 mm – 110 x 150 mm)

## Media specifications

- ✓ die-cut self-adhesive labels

- ✓ label/ribbon roll: 1.970' (600 m) material length
- ✓ label core: 3" (76 mm)

## Software

- ✓ software family (LogoPAL, LogoBatch, LogoMail, LogoTex)
- ✓ LEAP Express (label design)
- ✓ service and control tool (Control Center)
- ✓ status message via SMS with Control Center
- ✓ service-counter

## Environment

- ✓ operating temperature range: 5°C - 40°C
- ✓ special solution for ambient temperature
- ✓ humidity: 10% - 80 % relative, non-condensing
- ✓ power requirements: 110-230 VAC; 50/60 Hz
- ✓ air supply: 90 psi, 5.9 cfm, dry, clean and oil free
- ✓ CE certified, UL certification optional

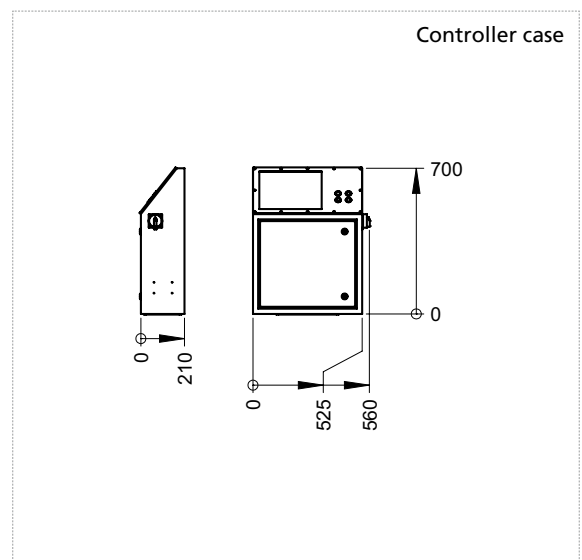
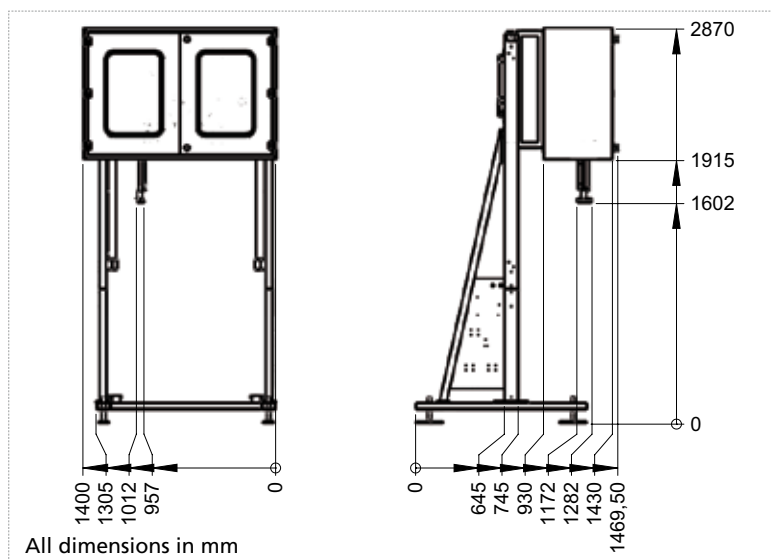

Dimensions refer to 50 mm label length and 300 mm telescope stroke.  
We reserve the right to amend the design and/or specifications of our product without notice.