

(00) 340382230000000009



Logopak 110 M

Automatic application of pre-printed labels



(00) 34038223000000009



Logopak 110 M

Features

- ✓ Up to 200 labels/min. (depending on label size)
- ✓ Model 110: up to 4.3" (110 mm) label width
- Model 115: up to 6.1" (156 mm) label width
- ✓ PLC interface with potential free I/O contacts

Operational features

- ✓ 4 digit LED display
- ✓ End of label roll sensor (option)
- ✓ 3-colored alarm pole (option)
- ✓ Self-learning mode for operation

Applicators

Model 110/115 M: Roll-on dispenser
 Model 110/115 T: Telescopic system
 Modell 110/115 B90: Blow-on system

Media specifications

- ✓ die-cut self-adhesive labels
- ✓ material length: 1.312' (400 m)
- ✓ label core: 2"/3"/6" (50/76/150) mm

Environment

- ✓ operating temperature range: 5°C – 40°C
- ✓ humidity: 10% – 80 % relative, non-condensing
- ✓ power requirements: 85 – 264 VAC; 47/63 Hz
- ✓ air supply: 90 psi, 5.9 cfm, dry, clean and oil free
- ✓ CE certified, UL certification optional

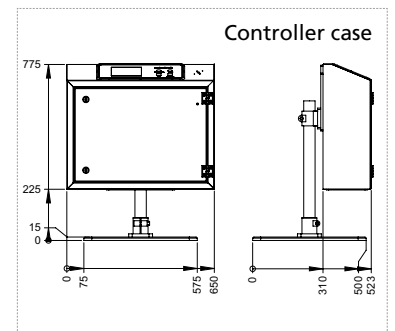
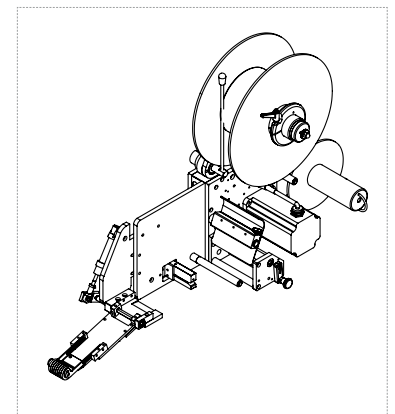
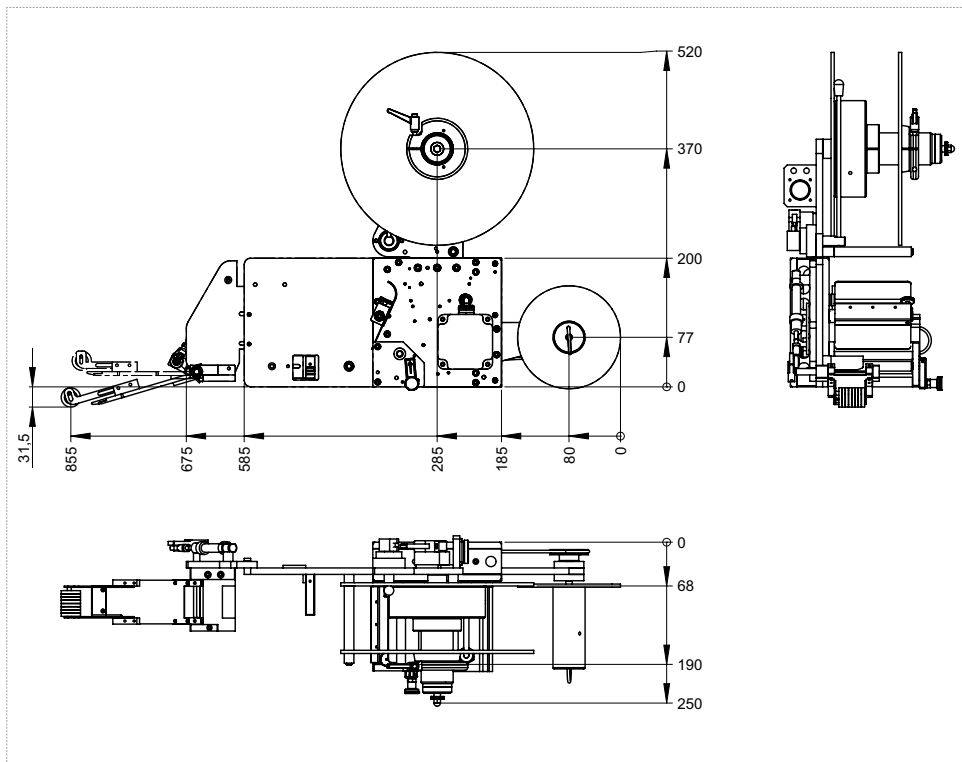

Technical modifications reserved.